

Hybrid Systems: Models, Simulation, and Testing

Norman Coleman, Steve Banks
 Robotics and Automation Laboratory
 US Army Armaments Research, Development and Engineering Center
 Building 95
 Picatinny Arsenal, NJ 07806-5000

John James
 Intermetrics, Inc.
 7918 Jones Branch Dr.
 Suite 710
 McLean, VA 22102 USA

Anil Nerode
 Mathematical Sciences Institute
 Whitehall
 Cornell University
 Ithaca, NY 14853-7901 USA

Wolf Kohn
 Intermetrics, Inc.
 1750 112th Ave NE
 Suite D-151
 Bellevue WA 98004 USA

james@potomac.wash.inmet.com

nerode@mssun7.msi.cornell.edu

wfk@minnie.bell.inmet.com

Abstract: Realization of the vision of a synthetic theater of war (STOW) fully depends on the creation of interoperable simulators, simulations, and fielded systems that *realistically* represent warfighting concepts, doctrine, forces and weapon systems of friendly, neutral and opposing forces. Distributed Interactive Simulations (DIS) have provided a wide variety of realistic training and analysis applications but cannot currently be relied upon to create the STOW because the architecture is known to have problems with synchronization, interoperability and scalability.

The revolution in military affairs implied by the DIS vision depends on commanders trusting the simulation results. Additionally, the verification, validation and accreditation (VV&A) of new models must be rapid enough to meet the needs of national decision makers. We provide preliminary ideas concerning how a detailed model being develop as part of the Automation and Robotics program of the

U. S. Army Armaments Research, Development and Engineering Center can be applied to address current problems in DIS by providing a timely approach to both simulation implementation and VV&A. Such an approach can be used to provide standard design guidance for linking models into seamless simulation exercises. Existing models can be incorporated by creating the appropriate simulation agents, thereby providing backward compatibility.

We will provide an overview of the architecture being developed and details concerning how such low-level, detailed models can be integrated into distributed, agent-based architectures to support early development of flexible test products. Such test products can be made to mature with the engineering design to provide a more realistic set of test products for VV&A of new systems.

1. Basis for Incremental Verification Validation and Accreditation: One approach to a scalable

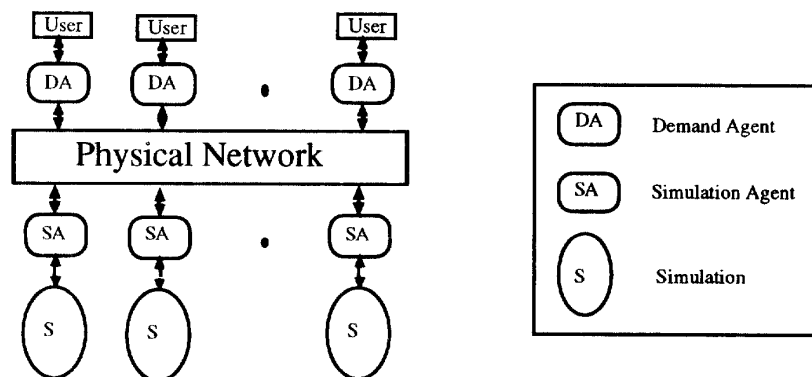

Figure 1. Multiple-Agent Hybrid Control Architecture

simulation architecture consists of a collection of *Simulation Agents* and *Demand Agents* interconnected via a general purpose communications network (see Figure 1). Our approach to control of hybrid systems addresses the issue of maintaining a consistent instantiation of the architecture by building mathematical foundations and creating a tool for implementing a **constructive algorithm for building automata which simultaneously comply with logical and evolution constraints**. Experimentation to determine system equilibria is still required, as is the need to experimentally verify that the high-level logic meets the needs of the users. However, the need for exhaustive experimentation to analyze the result of combining high-level logic and low-level evolution representations is not required since we generate programs which are consistent with the logical and evolution constraints. Thus to the extent that high-level, logic models are "trusted" and low-level continuous-time models are "trusted", we can construct automata which are consistent with constraints from both kinds of models. Furthermore, if the logic or evolution models are not completely compatible with the system they are modeling, the procedure provides for formal mechanisms for tuning the structure of the logic and evolution models. The proof capabilities for each agent in the multiple-agent architecture allows its to determine whether or not the local behavior of the system (as viewed by the agent) satisfies the requirements (the continuity condition) and if not, to modify reactively its plan so that requirement satisfaction (agreement set) is achieved. However, the on-line capabilities do not provide an effective proof for determining if for the given goal class, the reachability set of the carrier manifold trajectories is abundant. By abundant we mean that, at each decision point, the agreement set is populated with at least one solution for all the command actions. This reachability problem is essentially the problem of the validation of the knowledge base of the agent.

2. Problem Domain: The Distributed Nature of Engagement of Multiple Targets by Multiple Weapon Systems

The Army intends to field a digital division by 1998. Capabilities of the digital division are yet to be fully determined. However, it is expected that future Army combat operations will increasingly involve coalition forces and that future Army missions will increasingly require conduct of operations other than war (OOTW), such as peacemaking, peacekeeping, humanitarian support, and humanitarian relief. Current plans to reduce force structure is driving the Army to investigate increasing flexibility of existing units to support a wide range of missions.

Innovative use of barriers to decrease mobility of opposing forces and active use of barriers to cause opposing forces to move in desired directions has been a historic discriminator between success and failure in war. Barriers, such as intelligent mines are often used to channel opposing forces into an area where they can be engaged by direct and indirect fire weapons of the combined arms team. Successful demonstration of command and control of advanced mines will provide commanders with a flexible, lightweight means of increasing combat effectiveness. The Army experts in mine warfare determine the critical operational issues and criteria for success of the intelligent minefield. Future efforts to coordinate results of our current demonstration of target engagement with the intelligent minefield would provide an opportunity to test concepts for dominating the maneuver battle with concepts for operational use of intelligent mines.

2.1. Architecture Development: Battlefield Environment Model

The *battlefield environment* (see Figure 2) consists of a Universe (a prespecified region of the plane, i.e. A closed surface of R^2), two types of objects (Friendly objects and Foe objects), and the rules which determine the reaction (the evolution of the state over time) of friend or foe objects given the current state (of friend and foe objects) and the context of the operational situation (set of logical inputs). The set of possible battlefield scenarios is the set of **sequences of friend and foe actions** (from initiation of the battlefield simulation until the friend and foe objects are in a terminal state) and **associated contexts** . For the purposes of this demonstration, we will have a limited set of friend objects (always three objects) and foe objects and a limited number of rules (equational clauses - see Section 5.1.1 and [44]) which determine the evolution of the state of the system. The model is deliberately constructed in order to reflect some of the actual conditions which occur on the battlefield but only at a level necessary to demonstrate the reasoning and behavioral capabilities of multiple-agent hybrid control.

3. Conclusion The structure of the multiple-agent demonstration and the scope of multiple-agent hybrid control theory admit the construction of a high-fidelity model which will *not be achieved* in the current multiple-agent demonstration. However, we are currently implementing the steps necessary to achieve integration of a detailed, high-fidelity model of direct and indirect fire weapons with a distributed, low-fidelity, multiple-agent models of multiple weapons. A goal of the research is to explicitly investigate how such a formalism will support

development of test products to assist in more flexible VV&A of complex simulation models.

[1] Kohn, W., J. James, and A. Nerode, "Multiple-Agent Reactive Control of Distributed Interactive Simulations (DIS) Through a Heterogeneous Network", Proceedings of the U.S. Army Research Office Workshop on Hybrid Systems and Distributed Interactive Simulations, p. 100-140, Research Triangle Park, NC, 28 Feb. - 1 Mar. 1994.

[2] Kohn, W., J. James and Anil Nerode, "Multiple-Agent Hybrid Control Architecture for the Target Engagement Process", Intermetrics Technical Report

for the ARPA Domain-Specific Software Architectures (DSSA) Program, McLean, VA, March, 1994.

[3] Butler, B., "DIS Architecture for Interoperability, Special Problem: Interoperability between Heterogeneous Visual Systems", Proceedings of the U.S. Army Research Office Workshop on Hybrid Systems and Distributed Interactive Simulations, p. 253-275, Research Triangle Park, NC, 28 Feb. - 1 Mar. 1994.

[4] Kohn, W., J. James, R. Modes, and A. Nerode, "Multiple-Agent Reactive Control of Distributed Interactive Processes (DIS): An Overview",

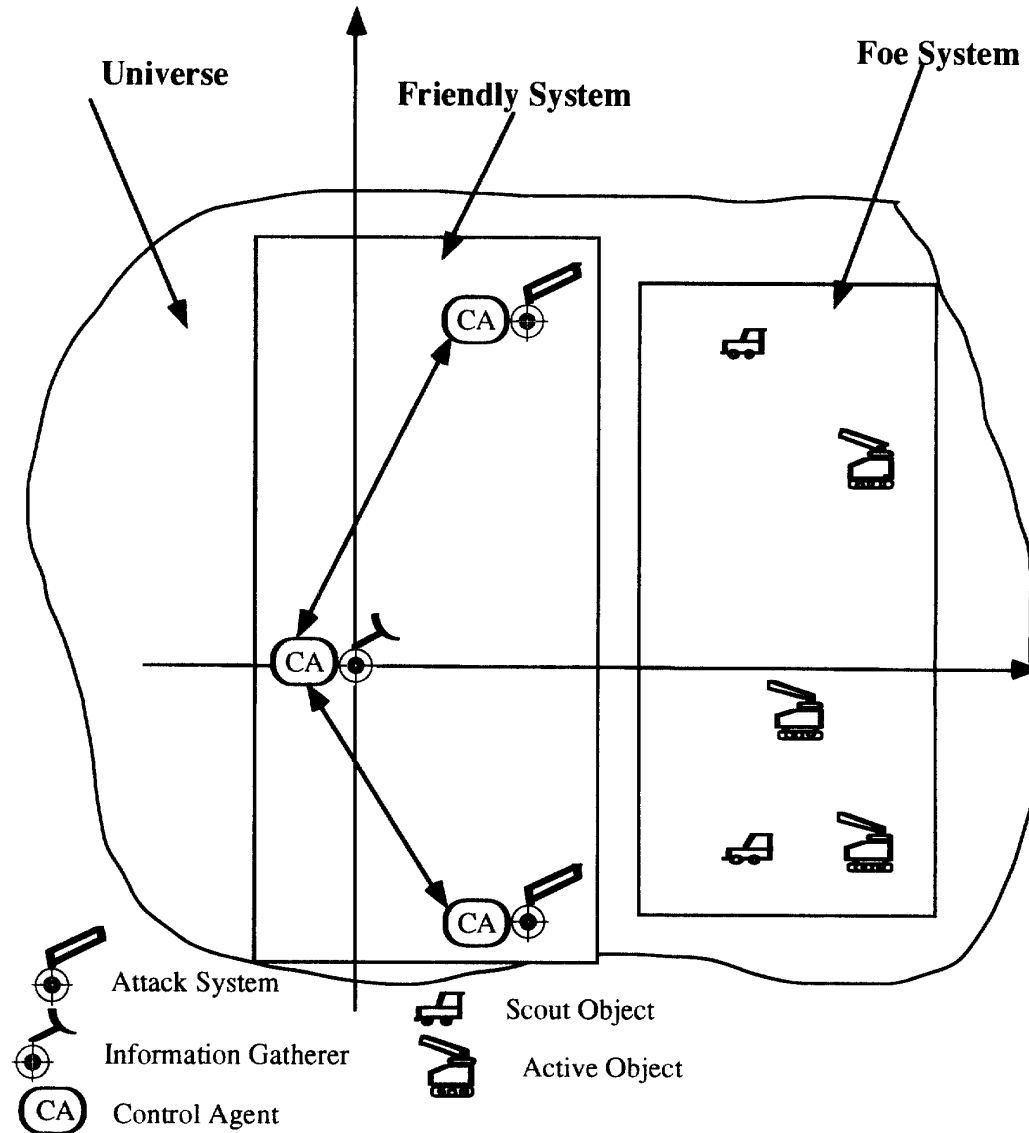

Figure 2. Battlefield Environment

Intermetrics, Inc., May, 1994.

[5] "Force XXI - A Talk With the Chief", Army, p. 28-34, May, 1994.

[6] Institute of Land Warfare, "Army Tests Info War", AUSA News, p. 7, June, 1994.

[7] Nerode A., Kohn W., " Multiple Agent Autonomous Control: A Hybrid Systems Architecture" Logical Methods In Honor of Anil Nerode's Sixtieth Birthday, N. C. Crossley , J. B. Remmel, M. E. Sweedler, Eds., Birkhauser, Boston, 1993.